

## Frame Assembly

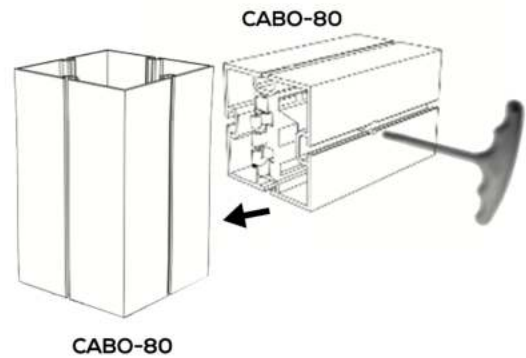

### CABO 80 Profile Connection

1. Line up lock with system groove on vertical profile
2. Insert teeth of lock into groove
3. Use torx tool to tighten lock (turn clockwise to tighten)

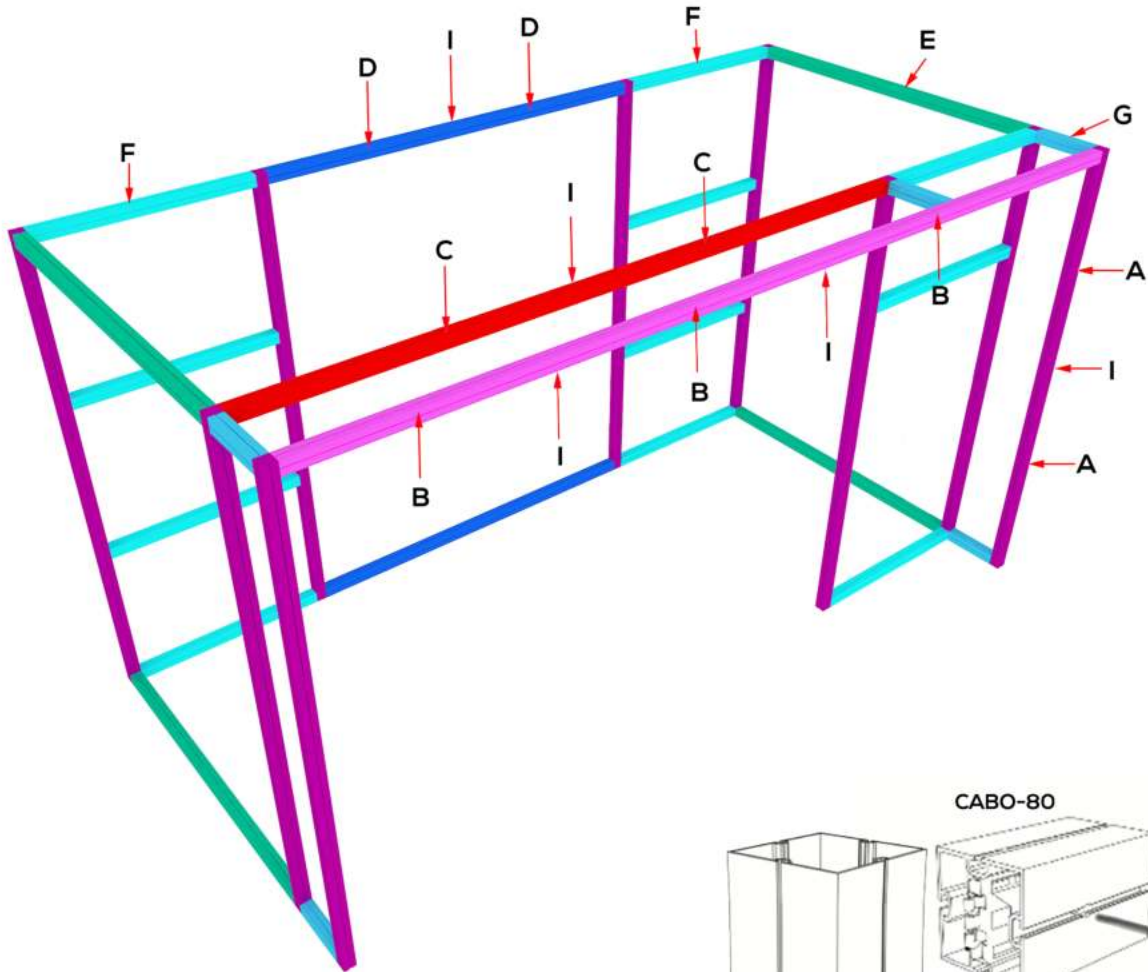
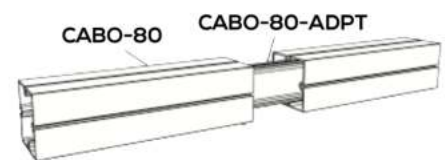

### CABO-80-ADPT Connection

1. Insert CABO-80-ADPT into one CABO-80 profile
2. Slide opposing CABO-80 profile onto CABO-80-ADPT
3. Tighten screws on CABO-80-ADPT to secure profiles in place

REF	SKU	QTY	LENGTH
A	CABO-80	18	66.65"
B	CABO-80	3	76.9"
C	CABO-80	2	86.1
D	CABO-80	4	56.9
E	CABO-80	4	94.3"
F	CABO-80	11	55.3"
G	CABO-80	5	16.3"
I	CABO-80-ADPT	14	n/a

## SEG Attachments

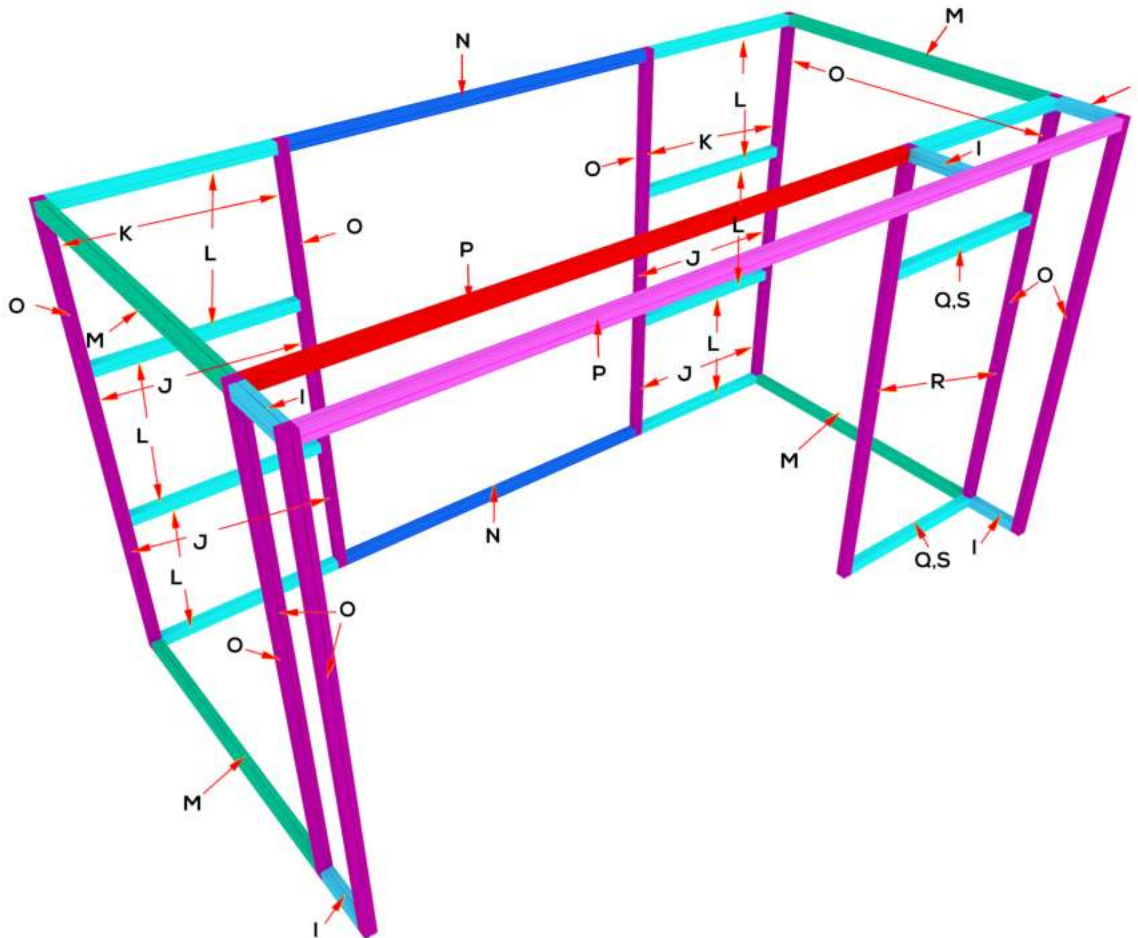

REF	SKU	QTY	LENGTH
I	CABO-SEG-PLASTIC	8	16.3"
J	CABO-SEG-PLASTIC	8	39.3"
K	CABO-SEG-PLASTIC	4	41.9"
L	CABO-SEG-PLASTIC	14	55.2"
M	CABO-SEG-PLASTIC	4	94.2"
N	CABO-SEG-PLASTIC	2	113.7"
O	CABO-SEG-PLASTIC	10	126.9"
P	CABO-SEG-PLASTIC	2	172.2"
Q	CABO-80-SEG	2	55.2"
R	CABO-80-SEG	2	94.4"
S	CABO-HHS	25	n/a

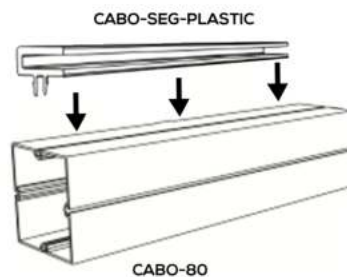

- CABO-SEG-PLASTIC Installation**
1. Line up clip of CABO-SEG-PLASTIC with system groove of profile
  2. Press CABO-SEG-PLASTIC down to lock into place.