

# MODCO-2

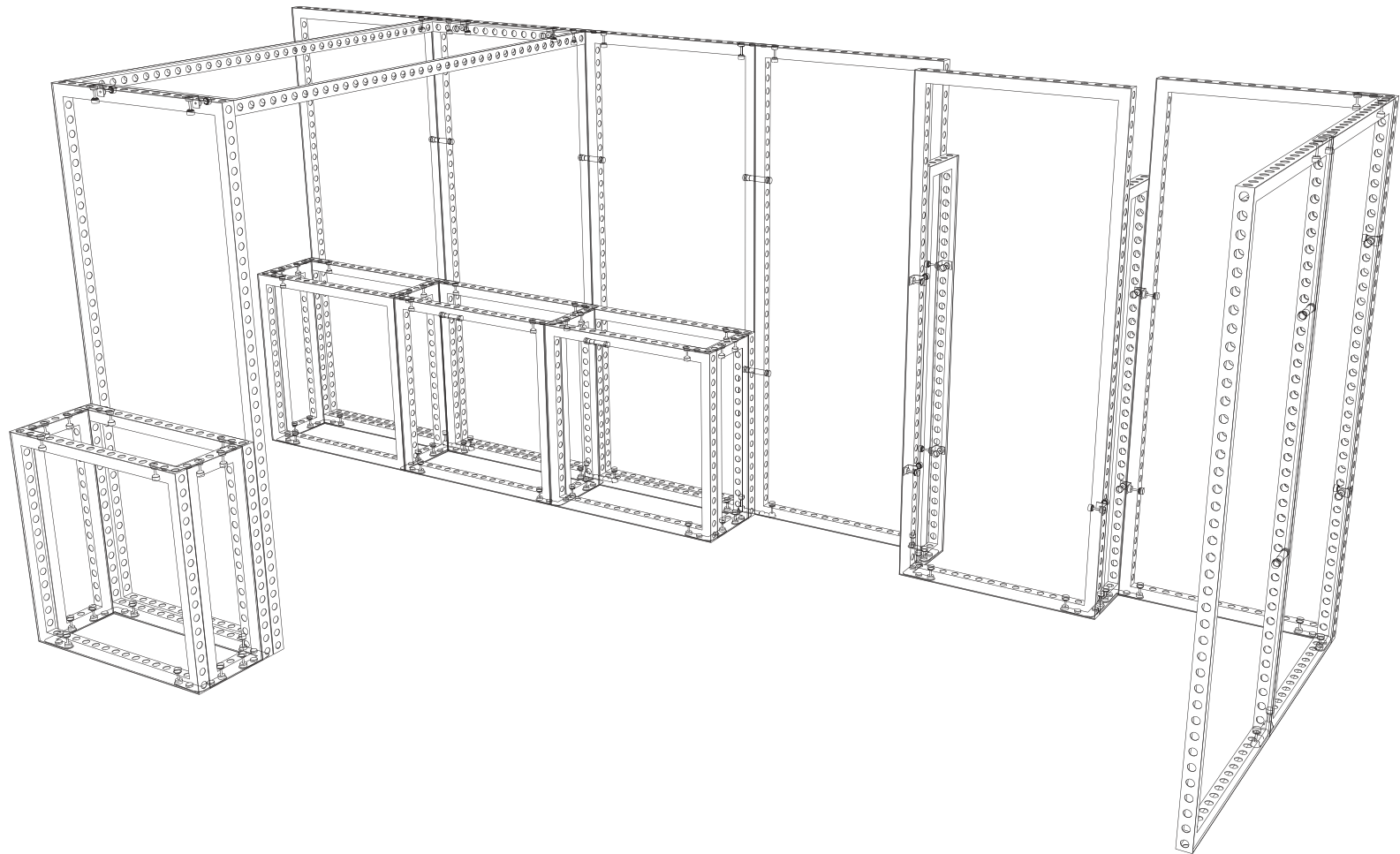

Instructions

## Parts / Frames

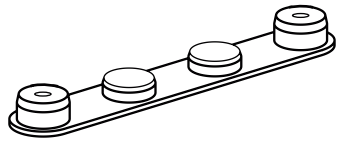

**180° Connector**  
MOD-180D-CON  
Qty.8

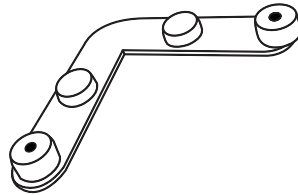

**90° Connector**  
MOD-SM90D-CON  
Qty.32

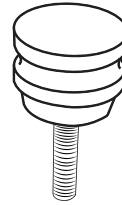

**Pin Connector**  
MOD-PC  
Qty.110

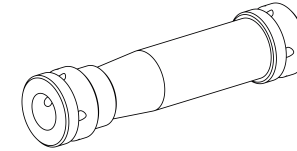

**Clamp Connector**  
MOD-CLA-CON  
Qty.16

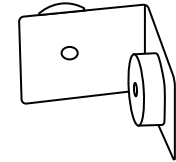

**90° Connector**  
MOD-90D-CON  
Qty.14



**310 x 992**  
MOD-FRM-310x992  
Qty.6

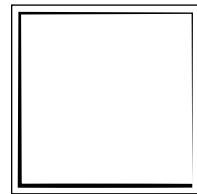

**992 x 992**  
MOD-FRM-992x992  
Qty.8



**310 x 1984**  
MOD-FRM-310x1984  
Qty.2

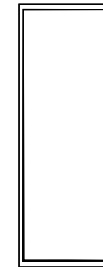

**992 x 2418**  
MOD-FRM-992x2418  
Qty.10



**Counter Shelves**  
MOD-PNL  
Qty.4

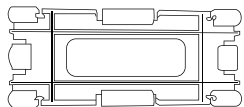

**Clip Connector**  
MOD-CC  
Qty.29



**17" Cover Profile**  
MOD-CP-3100  
Qty.2

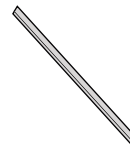

**39" Cover Profile**  
MOD-CP-3100  
Qty.8



**95" Cover Profile**  
MOD-CP-3100  
Qty.9

## Connections

# A

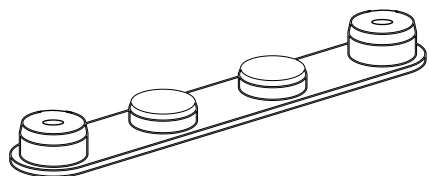

**MOD-180D-CON / MOD-PC**

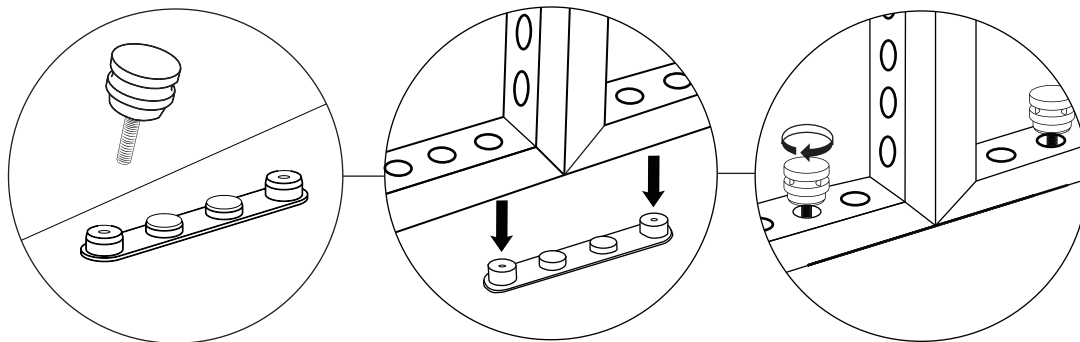

# B

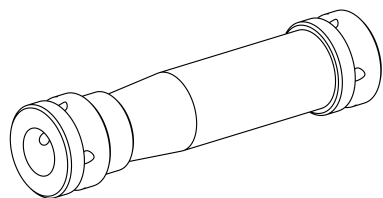

**MOD-CLA-CON**

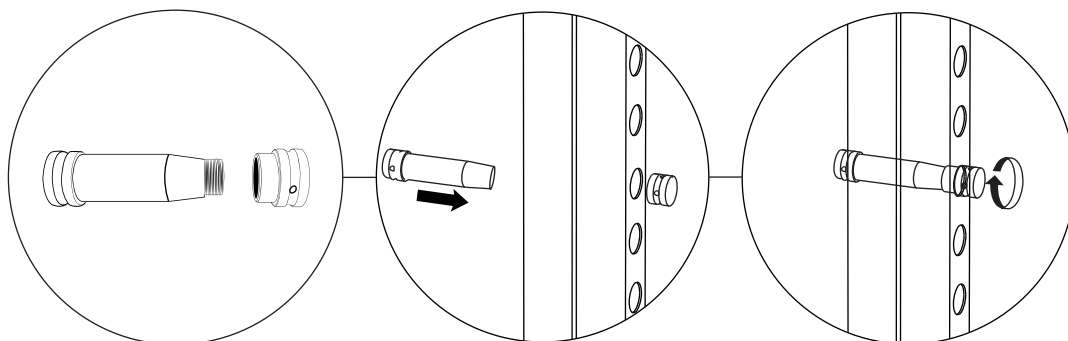

# C

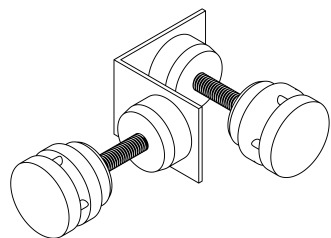

**MOD-90D-CON + MOD-PC**

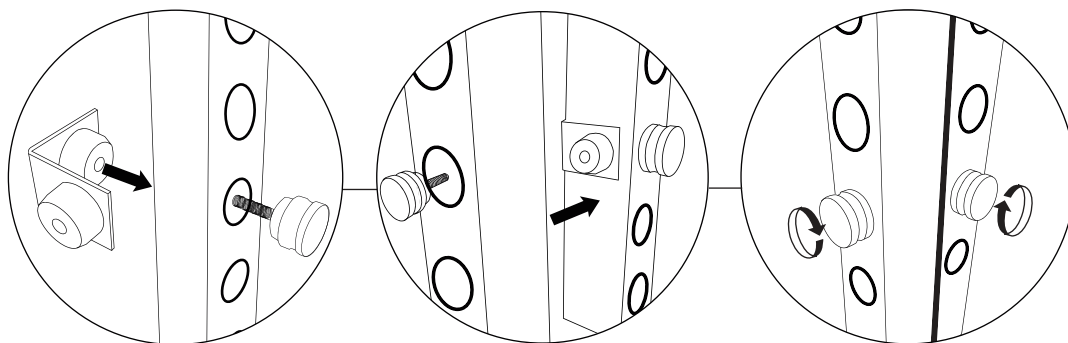

## Connections

# D

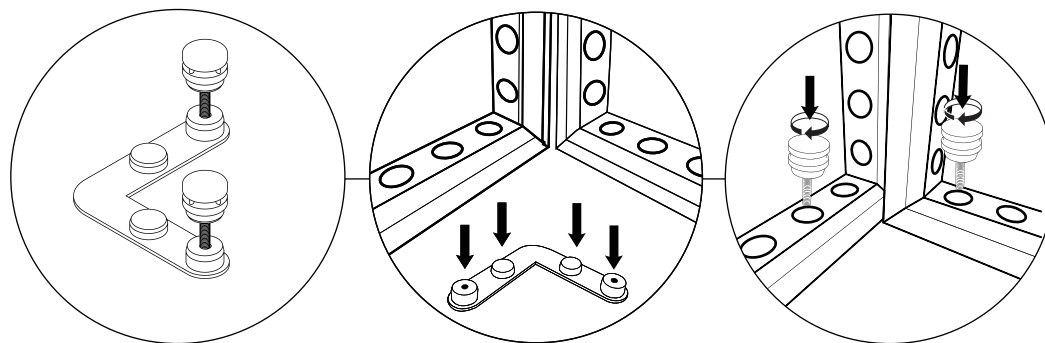
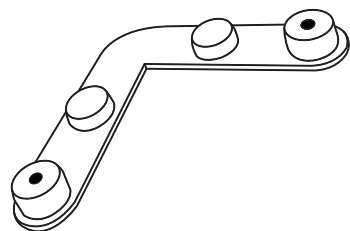

**MOD-SM90D-CON / MOD-PC**

## Cover Profiles

# E

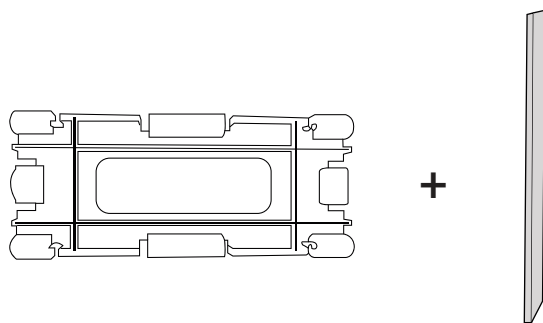

**MOD-CC / MOD-CP-3100**

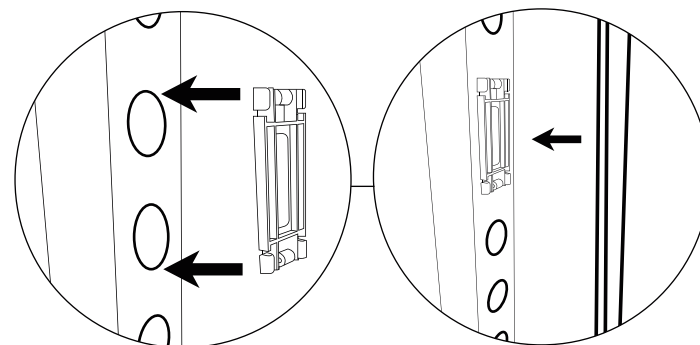

**1**

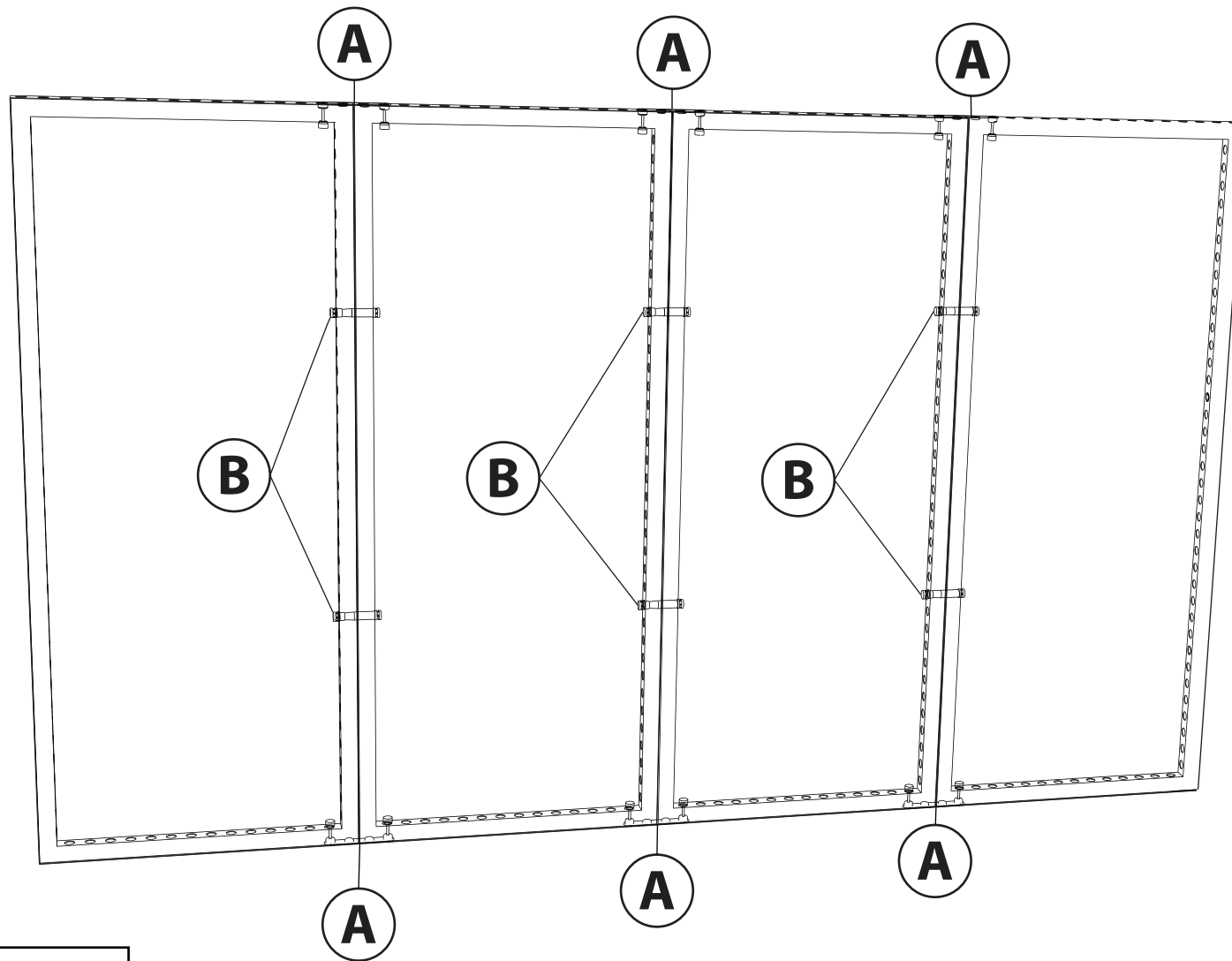

Qty.4 - MOD-FRM 992 x 2418  
Qty.6 - MOD-180D-CON  
Qty.6 - MOD-CLA-CON  
Qty.12 - MOD-PC

2

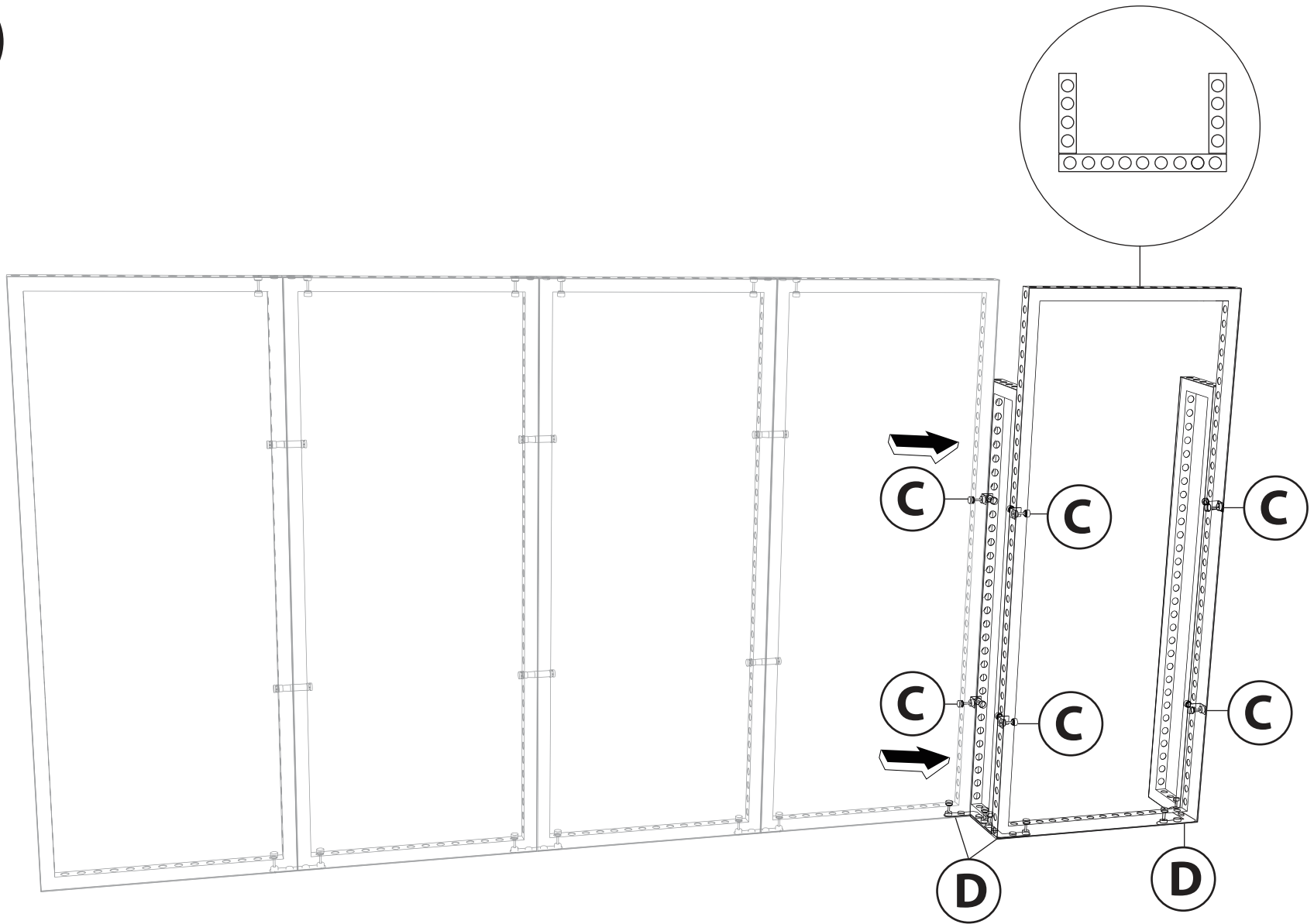

- Qty.1 - MOD-FRM 992 x 2418
- Qty.2 - MOD-FRM 310 x 1984
- Qty.6 - MOD-90D-CON
- Qty.3 - MOD-SM90D-CON
- Qty.18 - MOD-PC

Pre-install graphics on this section before connecting.  
(Graphic Install page)

**3**

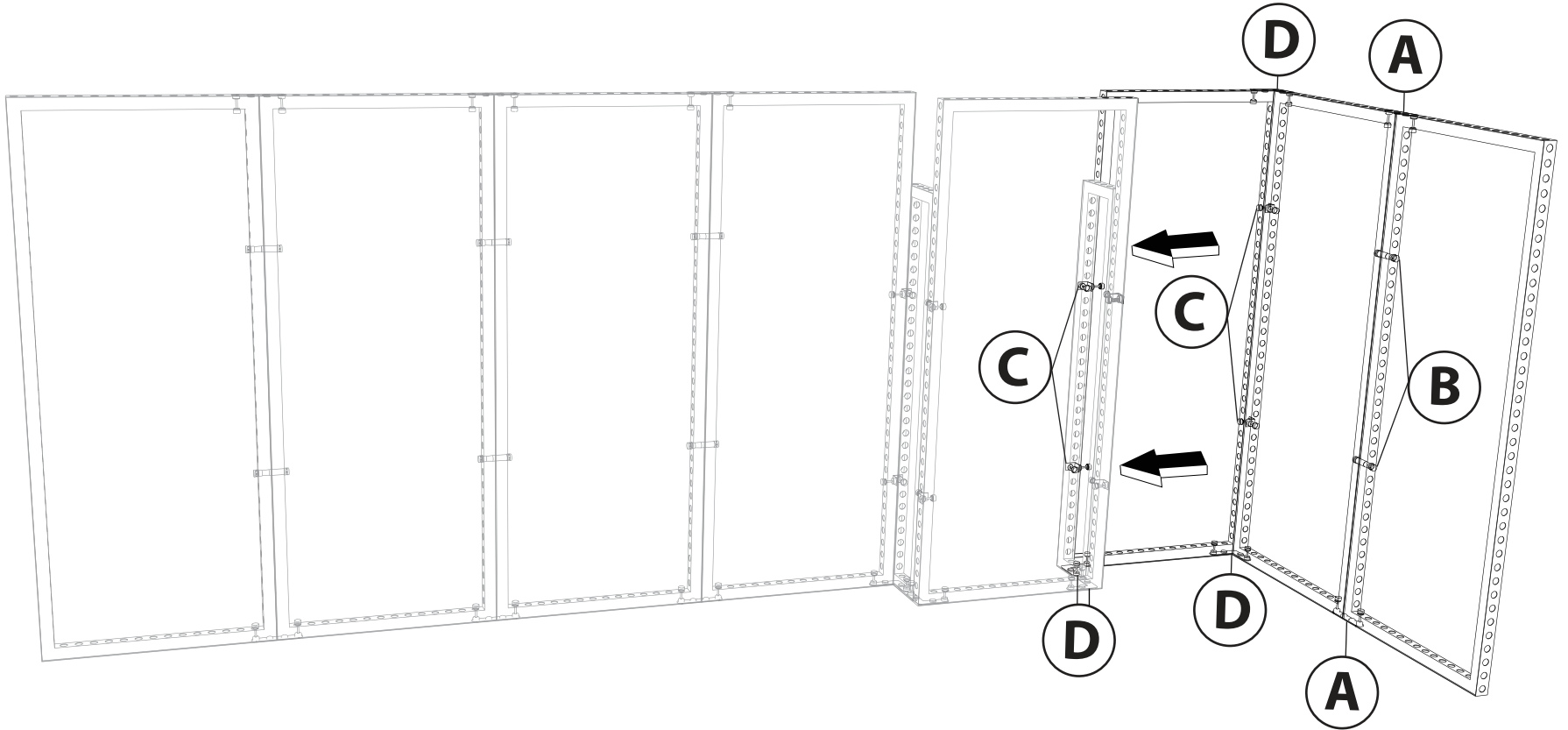

- Qty.3 - MOD-FRM 992 x 2418
- Qty.4 - MOD-90D-CON
- Qty.3 - MOD-SM90D-CON
- Qty.2 - MOD-180D-CON
- Qty.2 - MOD-CLA-CON
- Qty.20 - MOD-PC

4

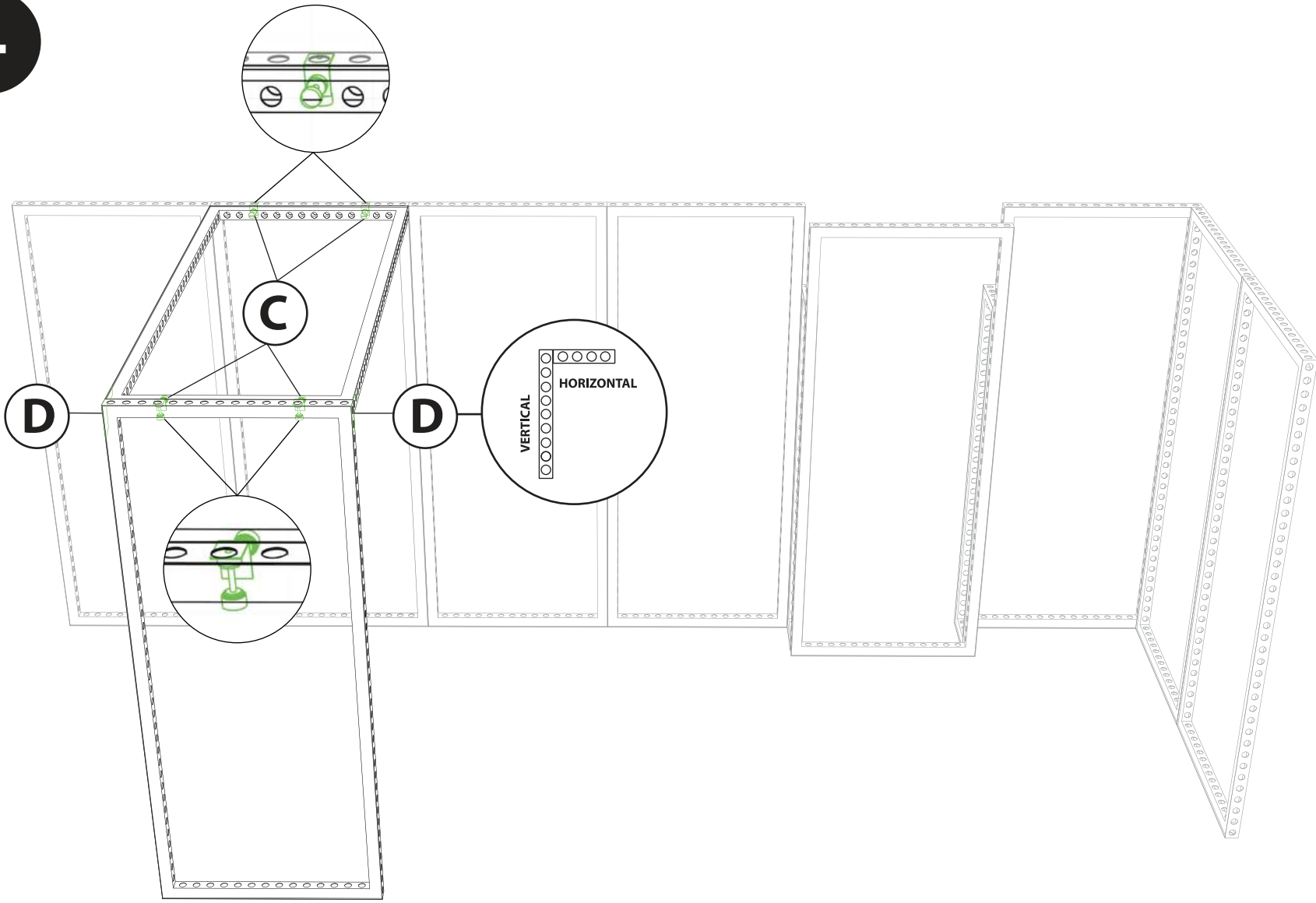

- Qty.2 - MOD-SM90D-CON
- Qty.2 - MOD-FRM 992 x 2418
- Qty.4 - MOD-90D-CON
- Qty.12 - MOD-PC

Pre-install graphics on top frame before connecting.  
(Graphic Install page)



**5**

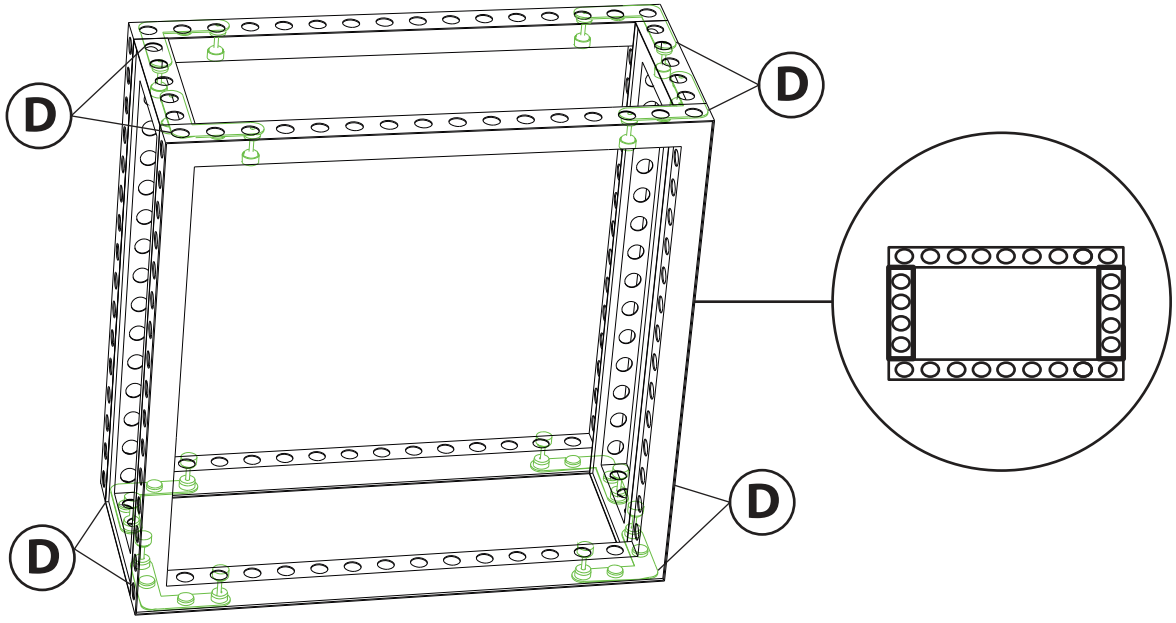

Qty.8 - MOD-FRM 992 x 992  
Qty.6 - MOD-FRM 310 x 992  
Qty.8 - MOD-CLA-CON  
Qty.24 - MOD-SM90D-CON  
Qty.48 - MOD-PC

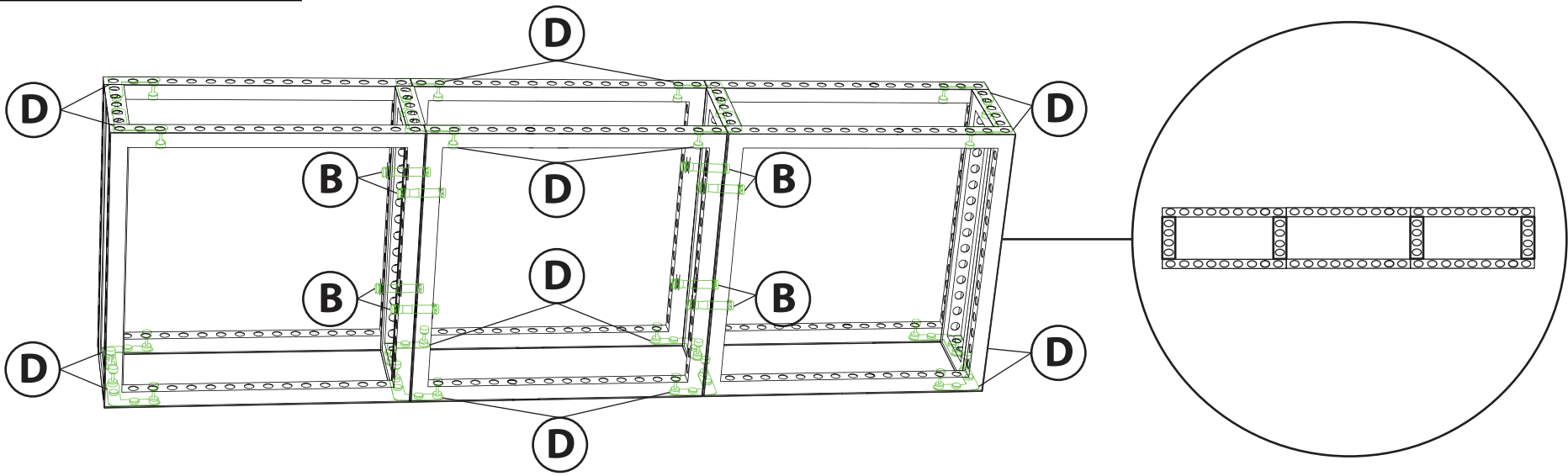

6

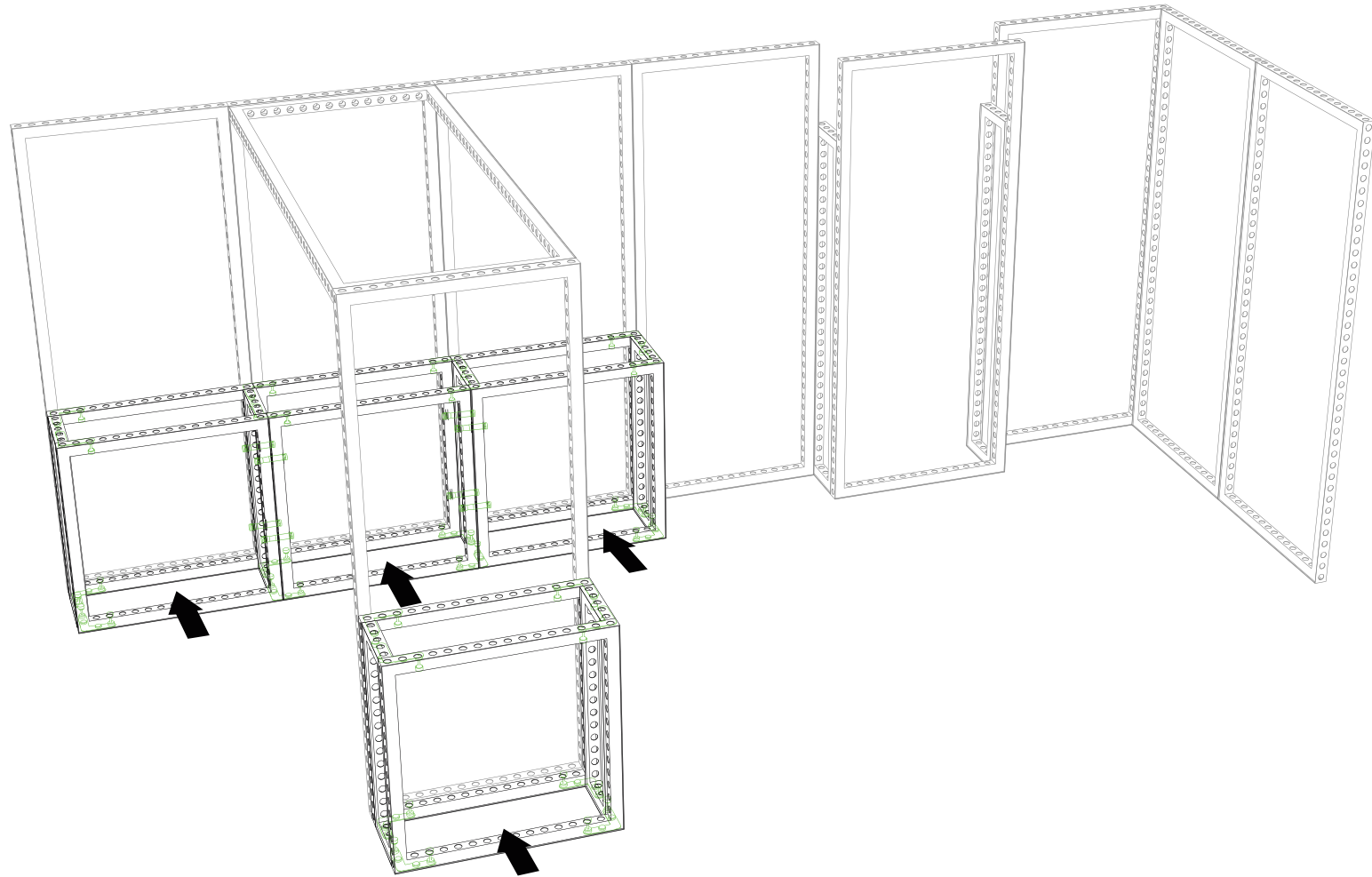

**Counters are independent / DO NOT ATTACH TO MAIN FRAME.**

# Cover Profiles

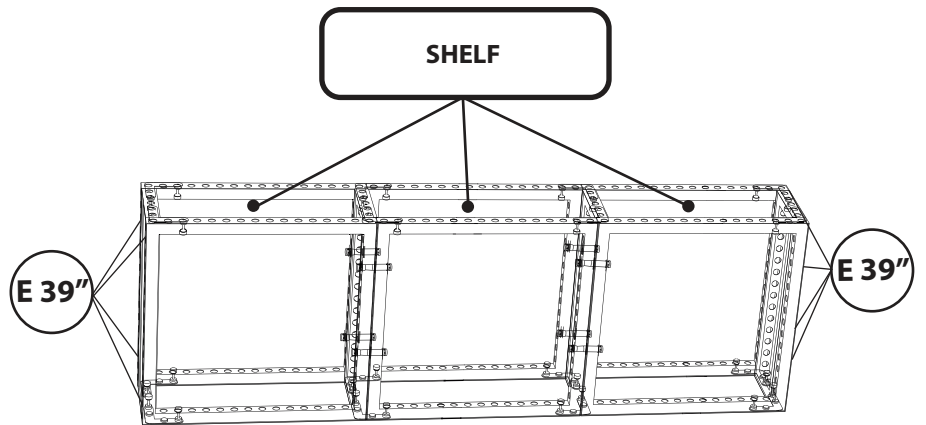
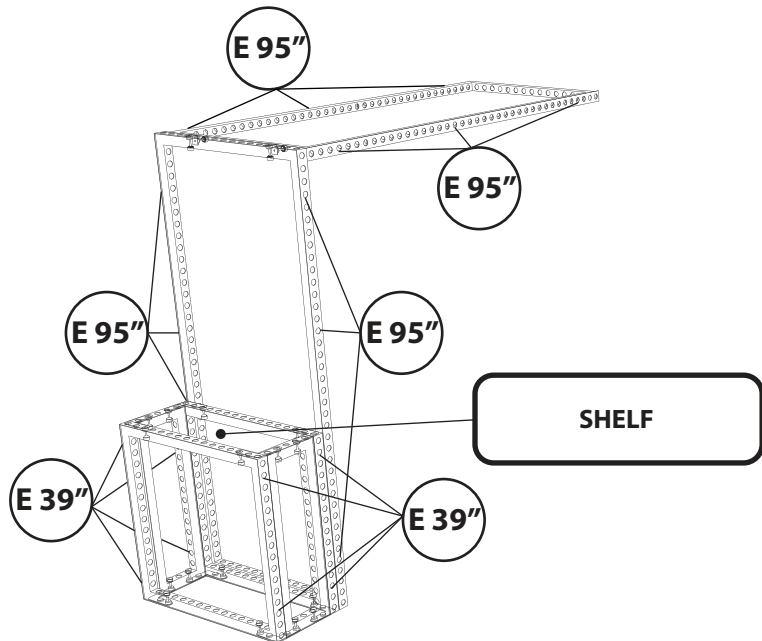
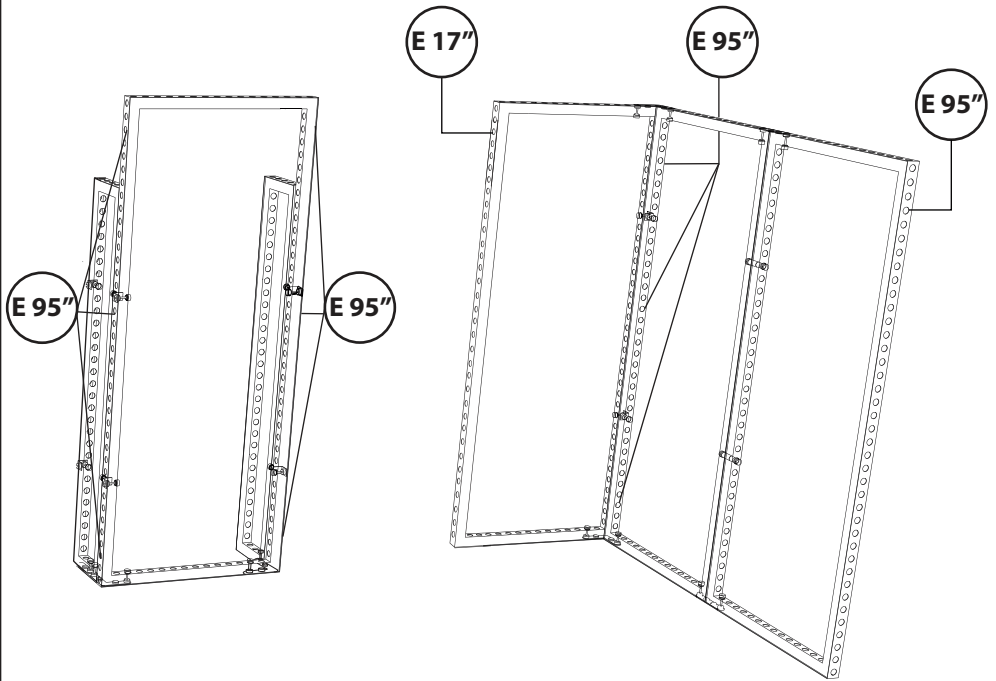
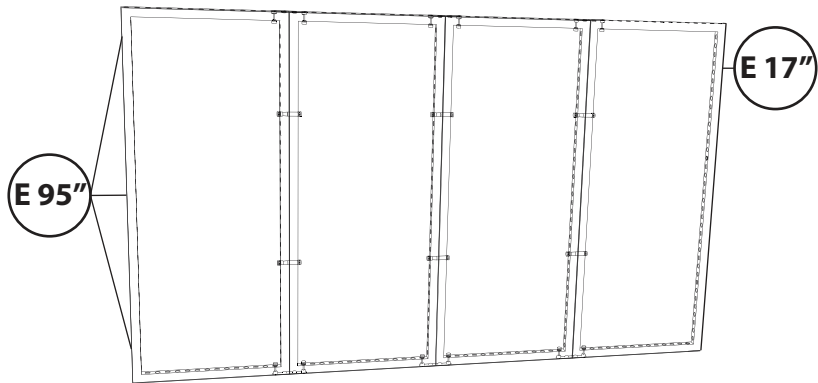

## Graphic Install



Place graphic over the front of the frame.



Begin inserting SEG beading at each corner.



YES

NO

Insert the silicone beading with the fabric folded over. The silicone beading should not be exposed.

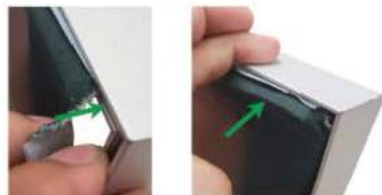

Using your fingers, push both fabric and silicone beading completely into the extrusions channel.



Continue to push in the remaining silicone beading on each side.



Check the perimeter of the frame for any excess beading that hasn't been pushed in. Graphic should be taut.