

MODCO - 2

MODCO MODULAR EXHIBITS
PRODUCT CODE: MOD-2

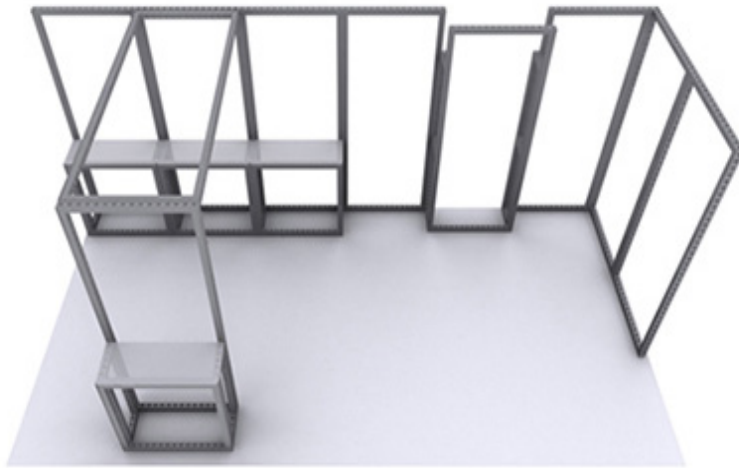

On frame On graphic



PRODUCT DESCRIPTION

Modco Modular Exhibits Modular 2 is a three-dimensional 20' x 10' pre-designed exhibit booth. Stylish and lively, Modco Modular Exhibits Modular 2 is built using tool-free perforated modular aluminum frames. Multiple size frames connect using simple toolless pin connectors. Use countertop to showcase your products. Customize double-sided stretch fabric SEG graphics for the entire exhibit. Perforations are completely covered for a flawless finish.

DISPLAY DIMENSIONS	234.3"W x 95"H x 117.3"D		
GRAPHIC SIZES	PANEL	SIZE	QTY
	A	157.25"W x 96.25"H	2
	B	13.25"W x 79.125"H	4
	C	40.125"W x 96.25"H	6
	D	79.25"W x 96.25"H	2
	E	118.125"W x 40.125"H	1
	F	13.25"W x 40.125"H	4
	G	40.125"W x 40.125"H	1
TOTAL PRINTS			21

GRAPHIC MATERIAL

Stretch Fabric w/Integrated Block Out

GRAPHIC FINISHING

Silicone beading is sewn around the perimeter of the fabric graphic. Silicone beading is hidden from view once installed.

DISPLAY CONSTRUCTION

Aluminum frame and components

SHIPPING WEIGHTS & DIMENSIONS (FREIGHT ONLY)

Shipping Weight	1040 lbs (frame and graphic)
Shipping Dimensions	102"L x 49.5"W x 44.5"H

GRAPHIC TURN AROUND TIME

5 business days after proof approval

AVAILABILITY	CA only
--------------	---------

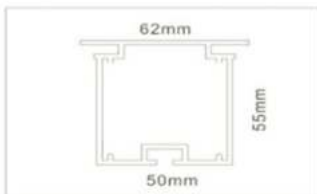

TEMPLATE GUIDE

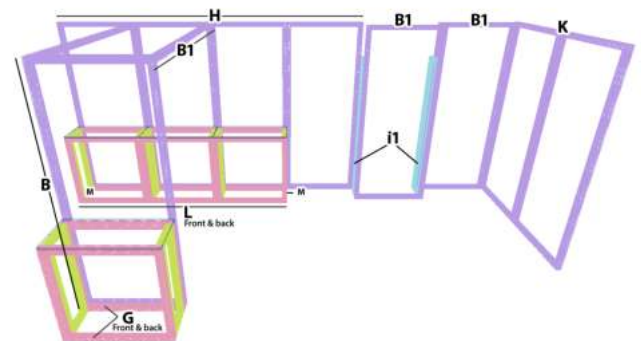

PARTS LIST

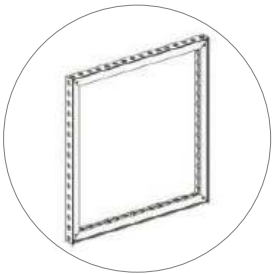

(qty 2)
MOD-FRM-310x1984

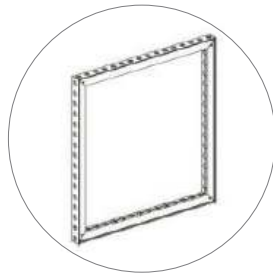

(qty 10)
MOD-FRM-992x2418

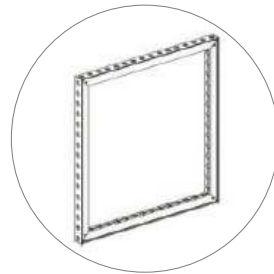

(qty 8)
MOD-FRM-310x992

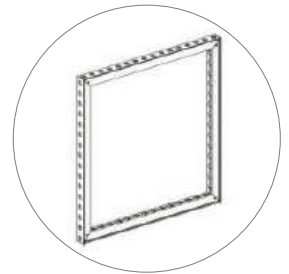

(qty 6)
MOD-FRM-992x992

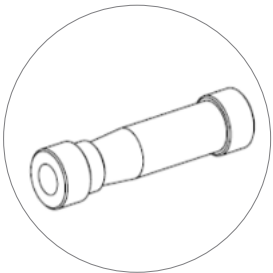

(qty 12)
MOD-CLA-CON

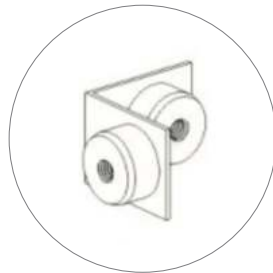

(qty 14)
MOD-90D-CON

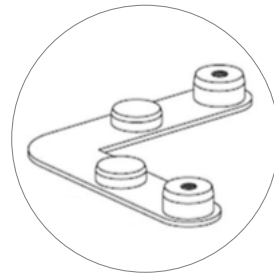

(qty 15)
MOD-SM90D-CON

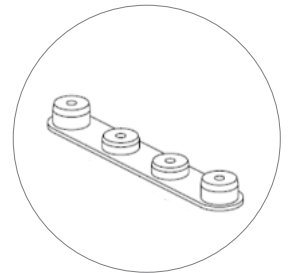

(qty 8)
MOD-180D-CON



(qty 104)
MOD-PC

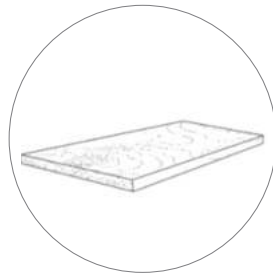

(qty 4)
MOD-PNL

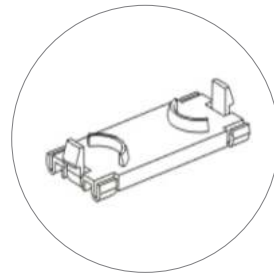

(qty 48)
MOD-CC



(qty 2)
17" MOD-CP-3100



(qty 9)
92.25" MOD-CP-3100



(qty 8)
39" MOD-CP-3100

SET UP INSTRUCTIONS

MODCO-2

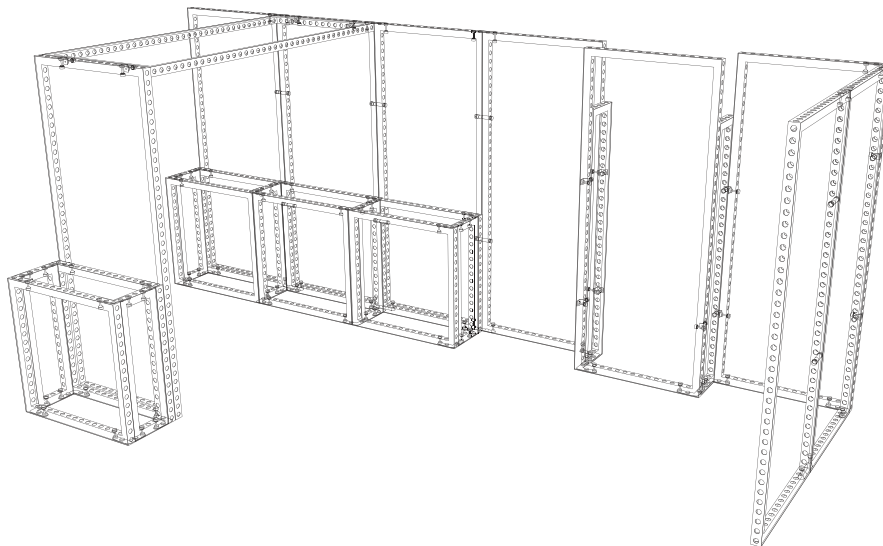

Instructions

Parts / Frames

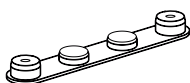

180° Connector
MOD-180D-CON
Qty.8

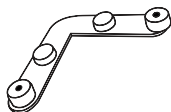

90° Connector
MOD-SM90D-CON
Qty.32



Pin Connector
MOD-PC
Qty.110

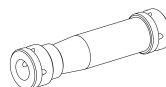

Clamp Connector
MOD-CLA-CON
Qty.16



90° Connector
MOD-90D-CON
Qty.14



310 x 992
MOD-FRM-310x992
Qty.6



992 x 992
MOD-FRM-992x992
Qty.8



310 x 1984
MOD-FRM-310x1984
Qty.2

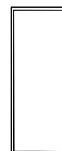

992 x 2418
MOD-FRM-992x2418
Qty.10



Counter Shelves
MOD-PNL
Qty.4



Clip Connector
MOD-CC
Qty.29



17" Cover Profile
MOD-CP-3100
Qty.2



39" Cover Profile
MOD-CP-3100
Qty.8



95" Cover Profile
MOD-CP-3100
Qty.9

Connections

A

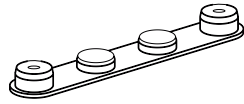

MOD-180D-CON / MOD-PC

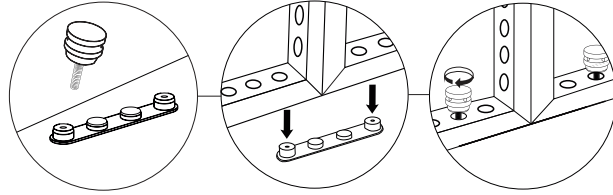

B

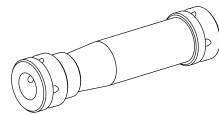

MOD-CLA-CON

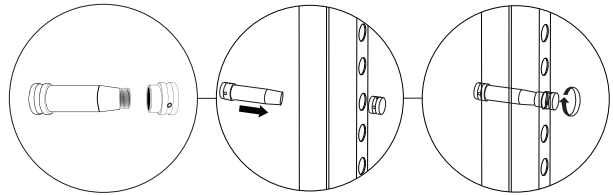

C

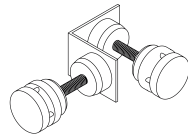

MOD-90D-CON + MOD-PC

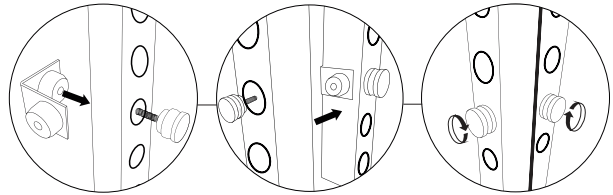

Connections

D

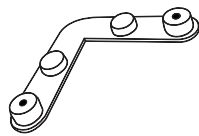

MOD-SM90D-CON / MOD-PC

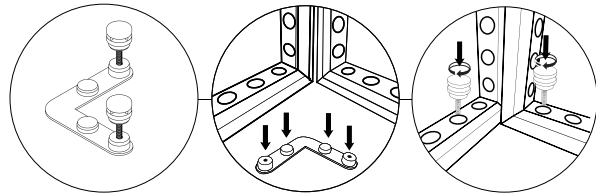

Cover Profiles

E

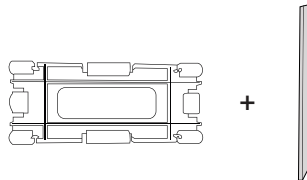

MOD-CC / MOD-CP-3100

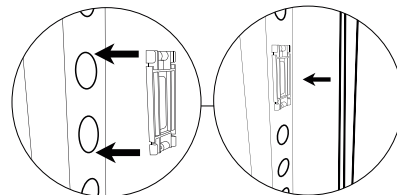

1

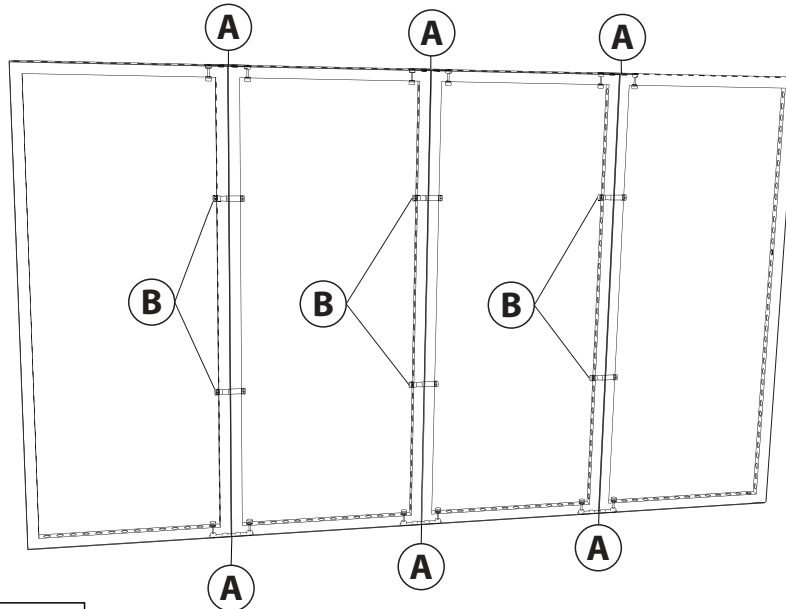

Qty.4 - MOD-FRM 992 x 2418
Qty.6 - MOD-180D-CON
Qty.6 - MOD-CLA-CON
Qty.12 - MOD-PC

2

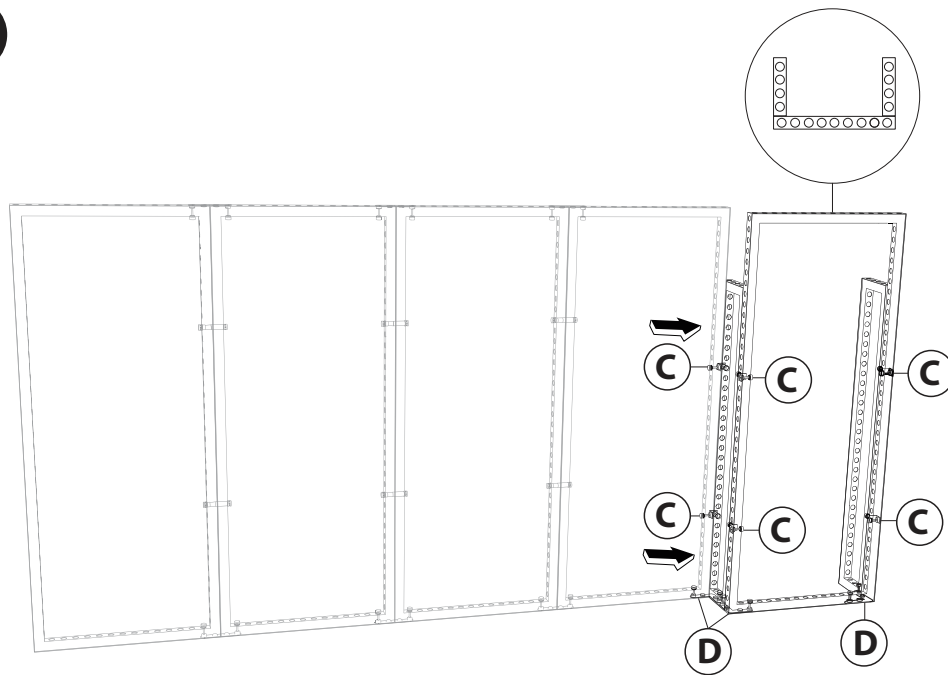

Qty.1 - MOD-FRM 992 x 2418
Qty.2 - MOD-FRM 310 x 1984
Qty.6 - MOD-90D-CON
Qty.3 - MOD-SM90D-CON
Qty.18 - MOD-PC

Pre-install graphics on this section before connecting.
(Graphic Install page)

5

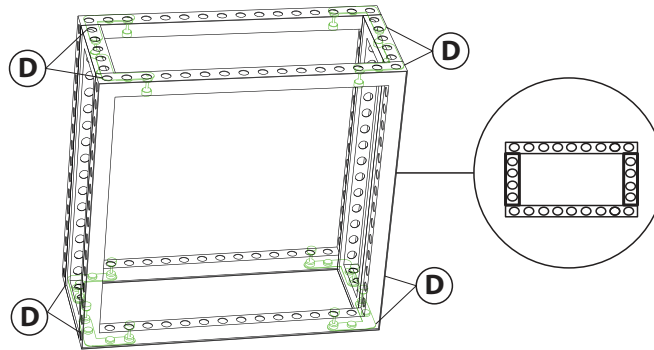

Qty.8 - MOD-FRM 992 x 992
Qty.6 - MOD-FRM 310 x 992
Qty.8 - MOD-CLA-CON
Qty.24 - MOD-SM90D-CON
Qty.48 - MOD-PC

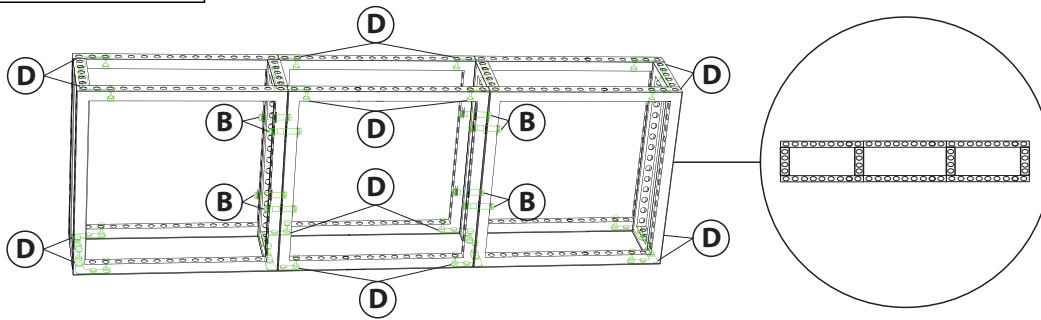

6

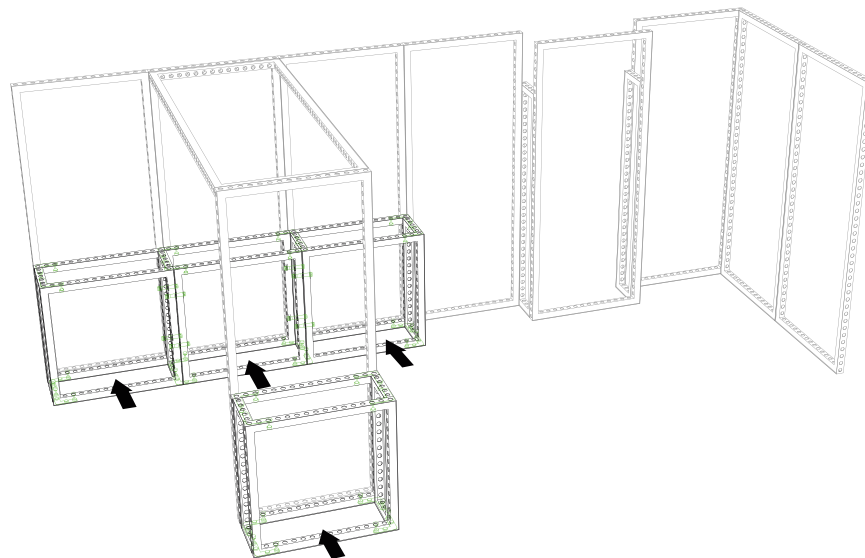

Counters are independent / DO NOT ATTACH TO MAIN FRAME.

Cover Profiles

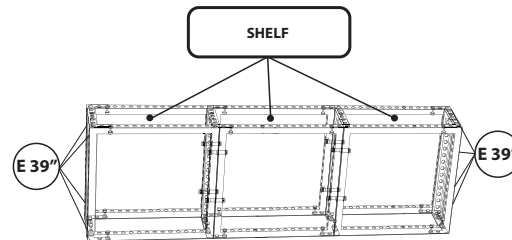
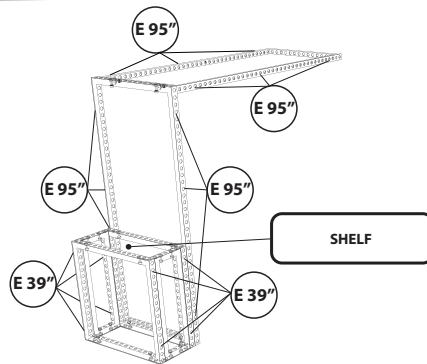
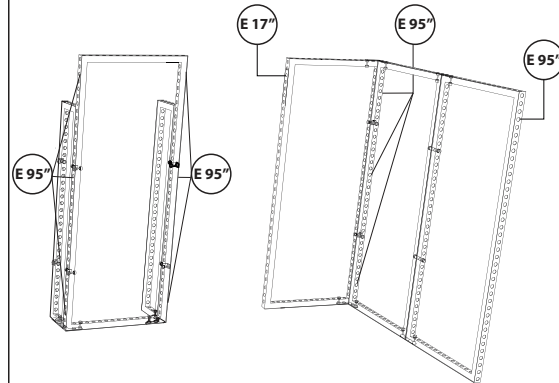
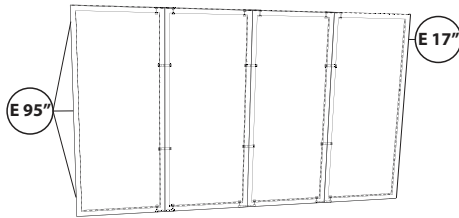

Graphic Install



Place graphic over the front of the frame.



Begin inserting SEG beading at each corner.



Insert the silicone beading with the fabric folded over. The silicone beading should not be exposed.



Using your fingers, push both fabric and silicone beading completely into the extrusions channel.



Continue to push in the remaining silicone beading on each side.



Check the perimeter of the frame for any excess beading that hasn't been pushed in. Graphic should be taut.