

MODCO 4-10x10

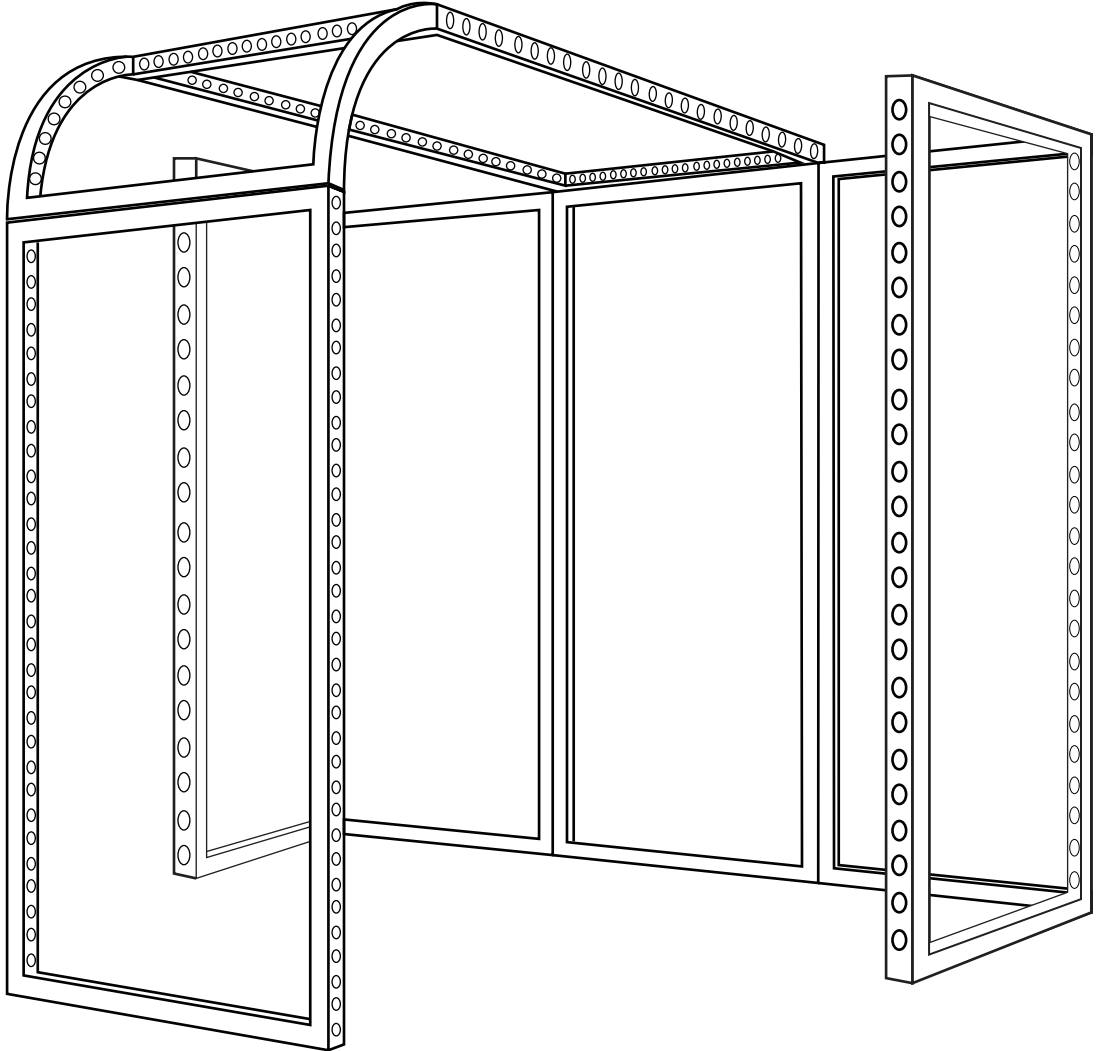

Instructions

Parts / Frames

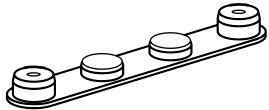

180° Connector
MOD-180D-CON
Qty.4

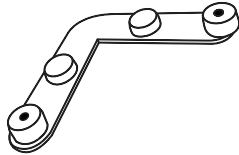

Small 90° Connector
MOD-SM90D-CON
Qty.4

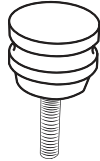

Pin Connector
MOD-PC
Qty.48



Door Pin Connector
MOD-PCDOOR
Qty.4

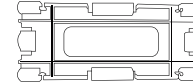

Clip Connector
MOD-CC
Qty.22

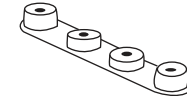

180° Curved Connector
MOD-CRV-180DCL Qty.2
MOD-CRV-180DCR Qty.2

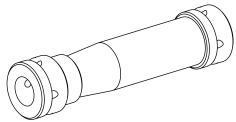

Clamp Connector
MOD-CLA-CON
Qty.4

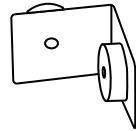

90° Connector
MOD-90D-CON
Qty.10



1/4 Curved Cover Profile
MOD-CP-774
Qty.2

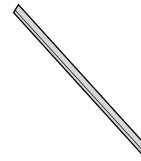

58" / 78" Cover Profile
MOD-CP-3100
Qty.2 - 58" / Qty.2 - 78"



95" Cover Profile
MOD-CP-3100
Qty.4

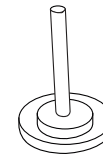

Pin Connector for Profile Cover
MOD-PCWP-B
Qty.4



28mm Screw Nut
MOD-SN28MM
Qty.4

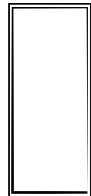

992 x 1984
MOD-FRM-992x1984
Qty.1

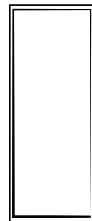

992 x 2418
MOD-FRM-992x2418
Qty.6



992 x 992
MOD-CRVFRM-774x992
Qty.1

Connections I

A

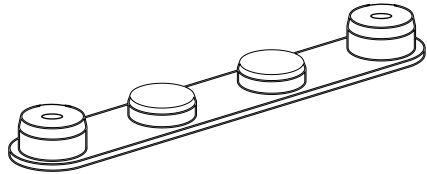

MOD-180D-CON / MOD-PC

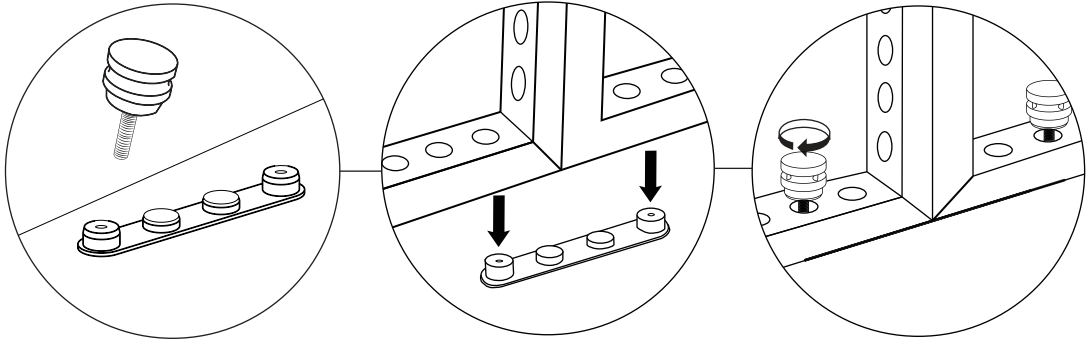

B

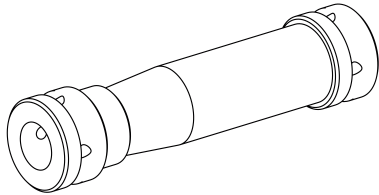

MOD-CLA-CON

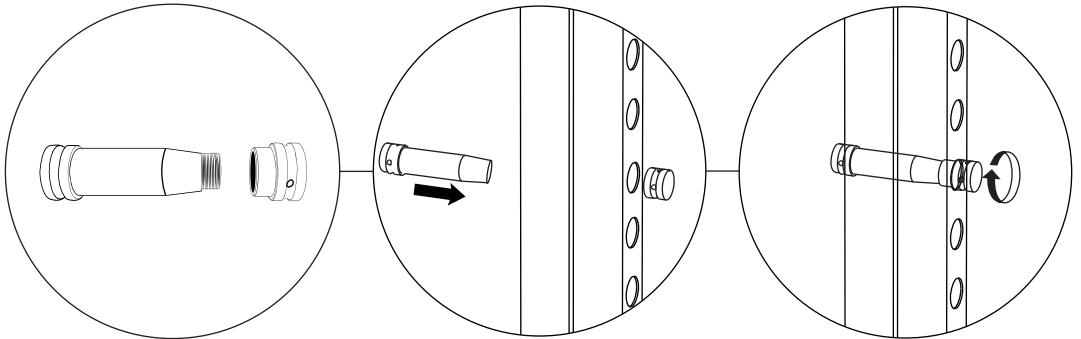

C

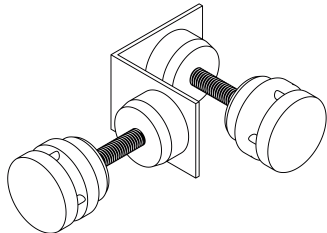

MOD-90D-CON + MOD-PC

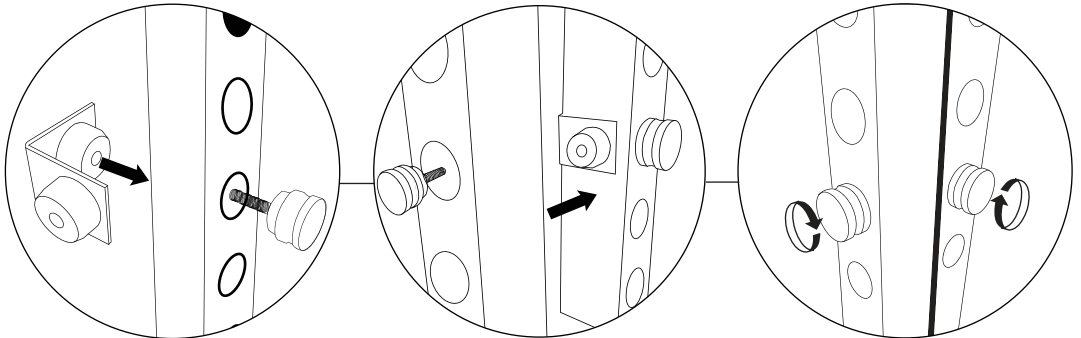

Connections II

D

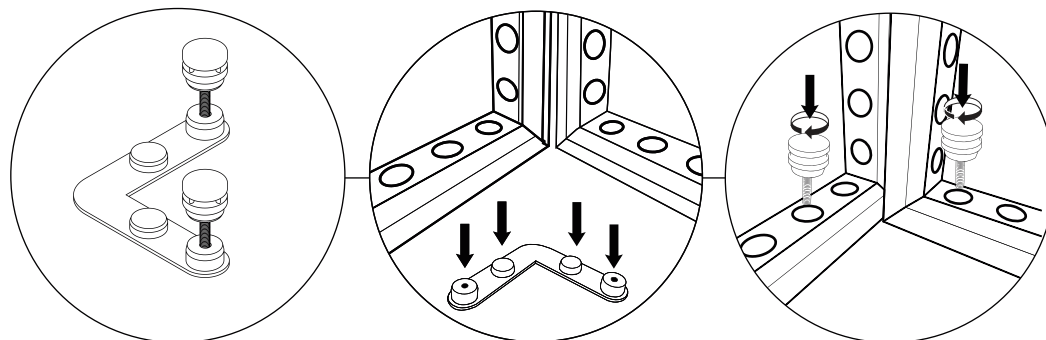
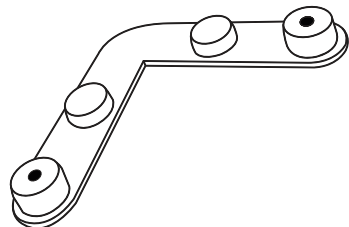

MOD-SM90D-CON / MOD-PC

E

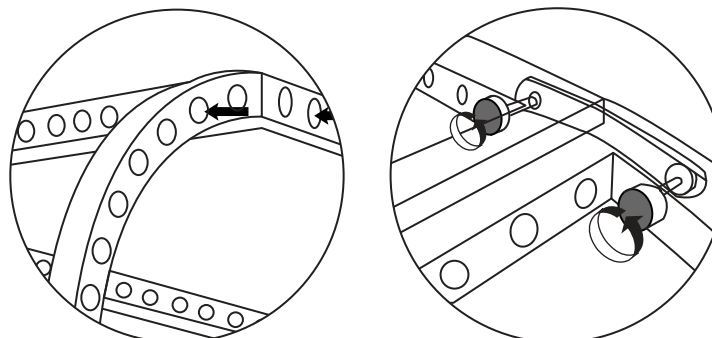
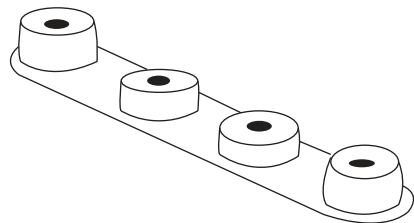

MOD-CRV-180DC / LEFT & RIGHT

OUTSIDE

INSIDE

F

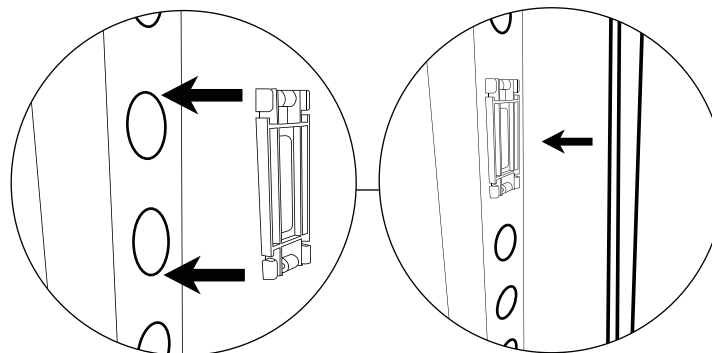
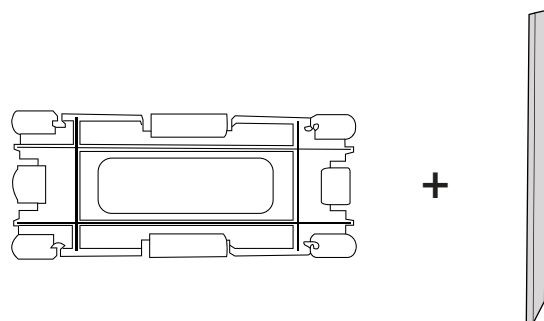

MOD-CC / MOD-CP-3100

Connections III

G

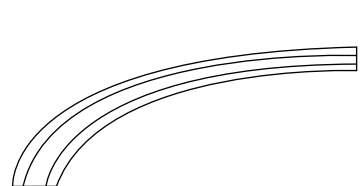

MOD-CP-774

+

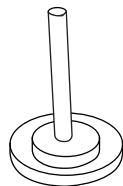

MOD-PCWP-B

+



MOD-SN28MM

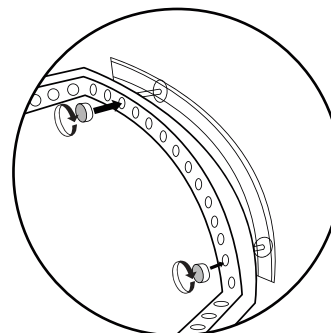
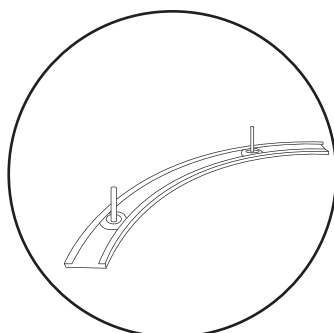
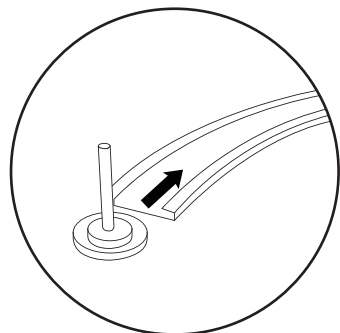

1

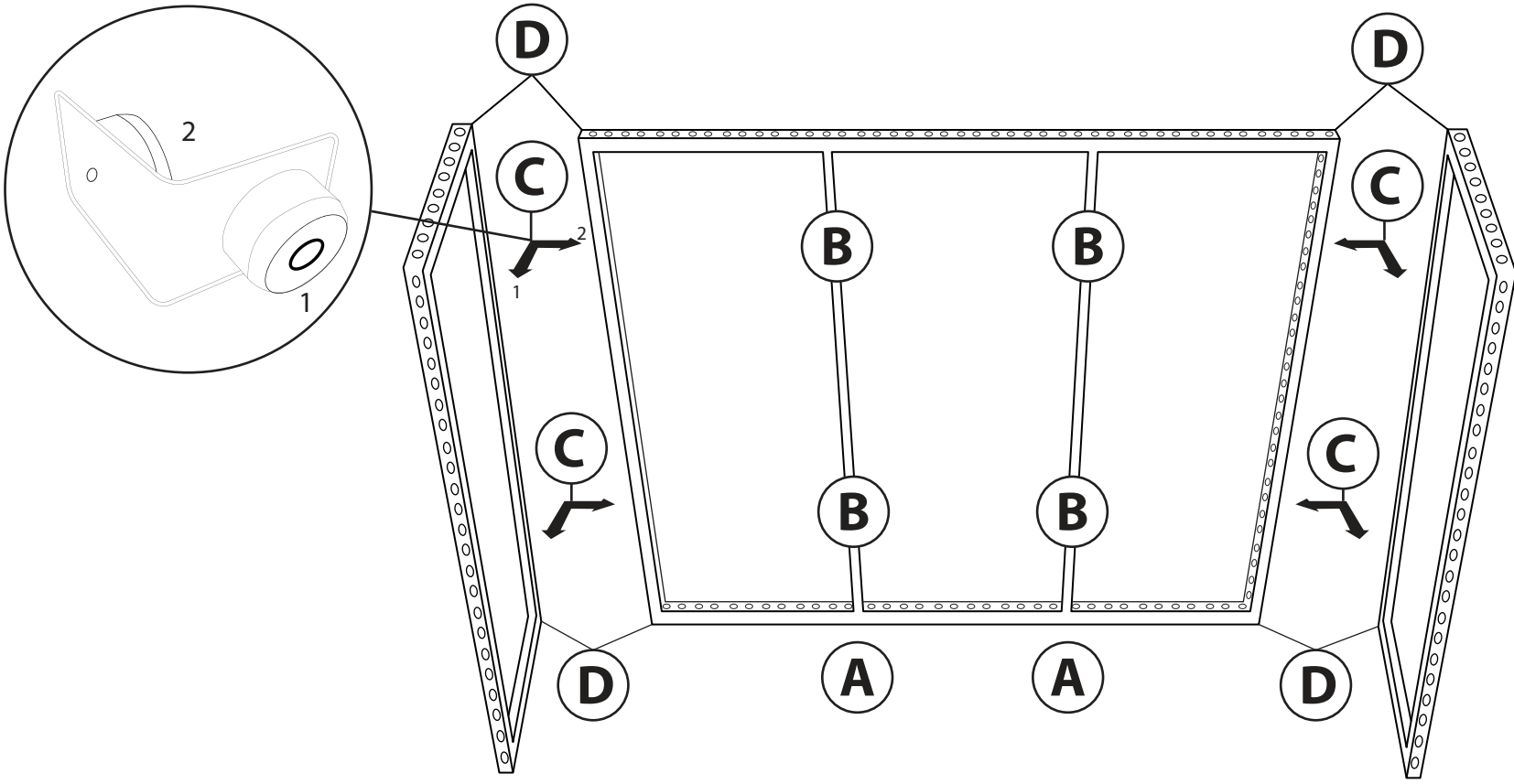

**Attach (3) MOD-FRM-992x2418 in a row.
Next, attach (1) MOD-FRM-992x2418 to each adjacent side of the row - (2) sides total.
Reference the diagram above.**

2

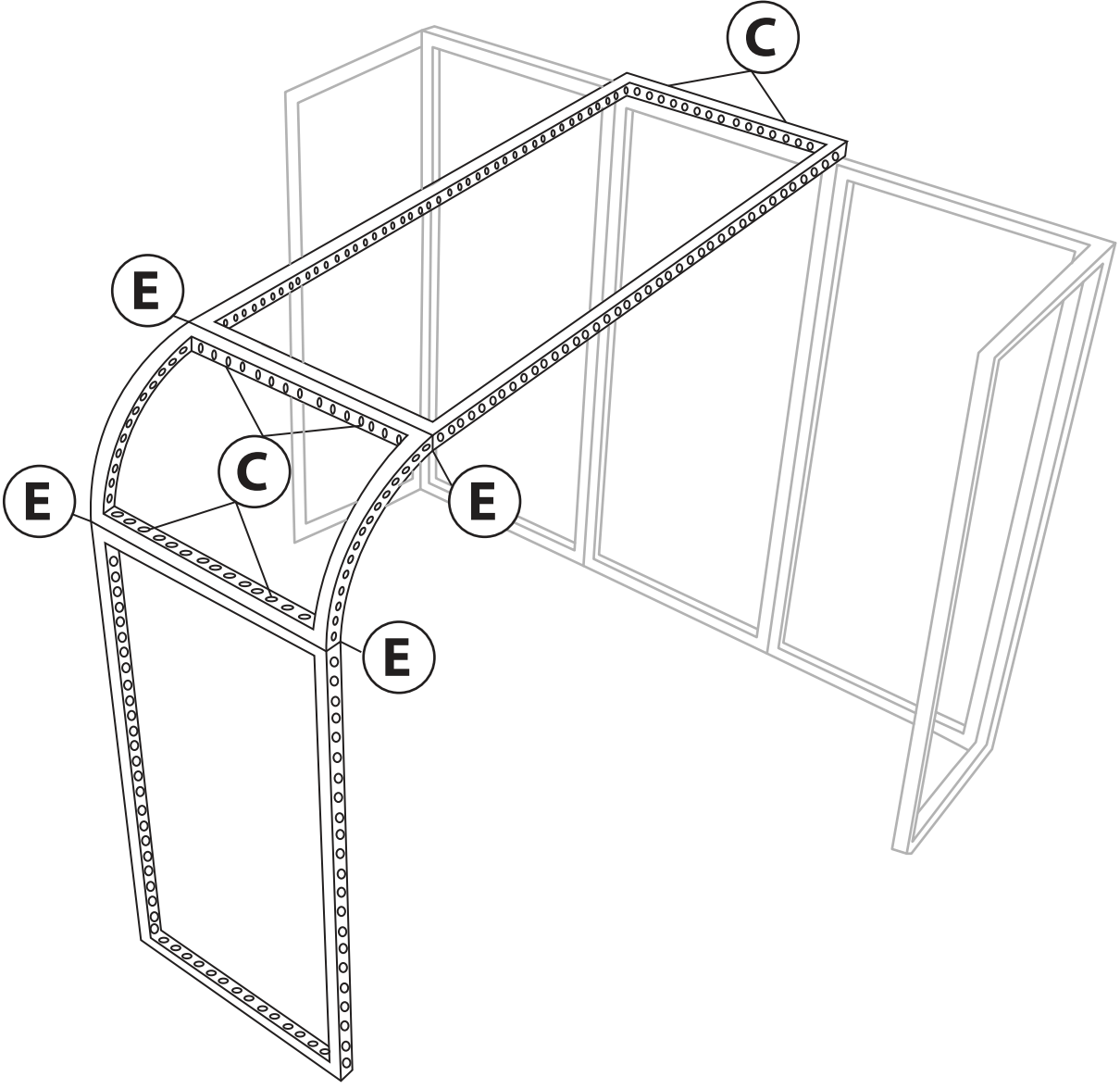

Cover Profiles

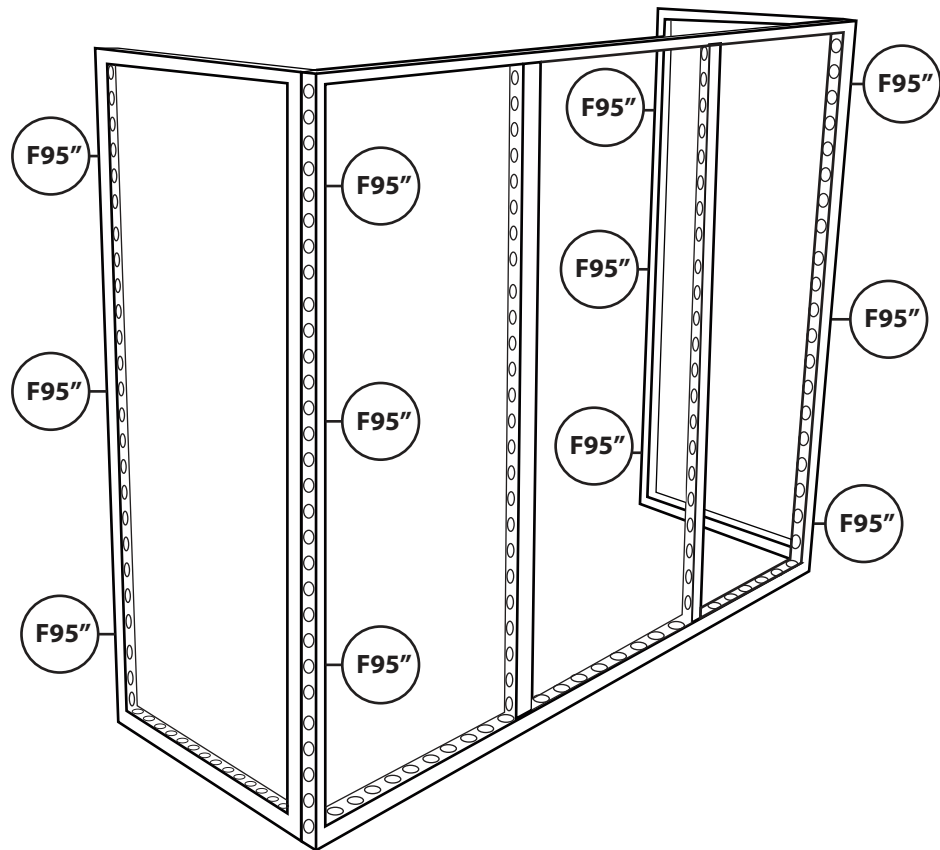
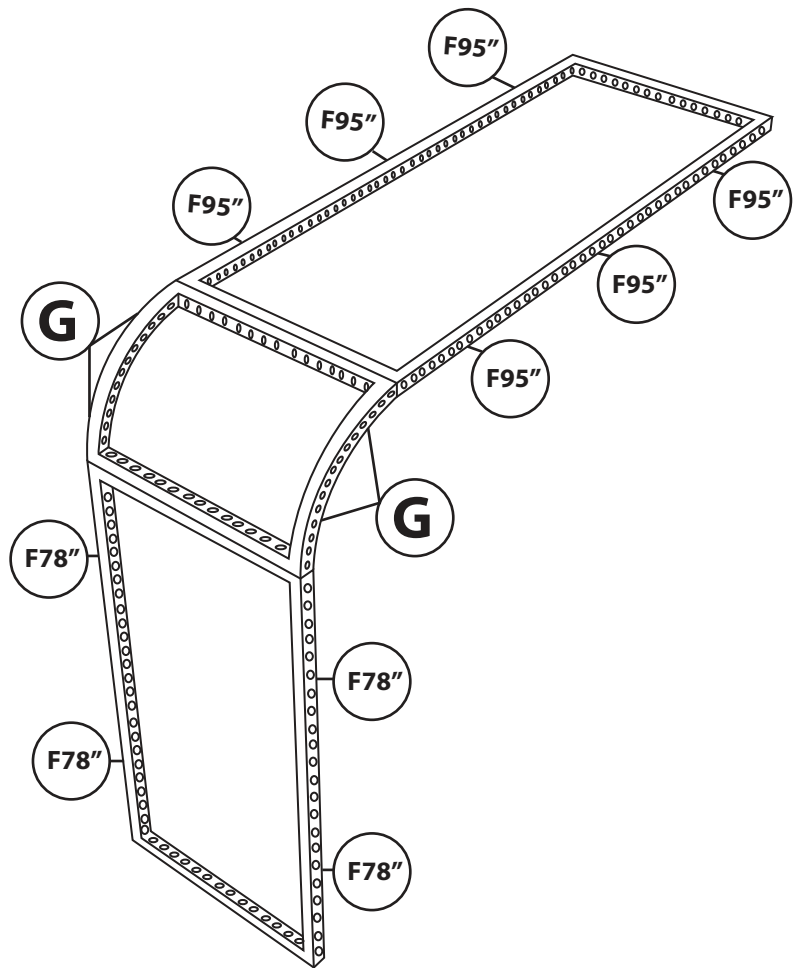

Snap in clip connectors at each designated point and then reference the measurement and install the cover profile.
*Overhead view - clip connectors/cover profiles to back side of configuration.

Graphic Install



Place graphic over the front of the frame.



Begin inserting SEG beading at each corner.

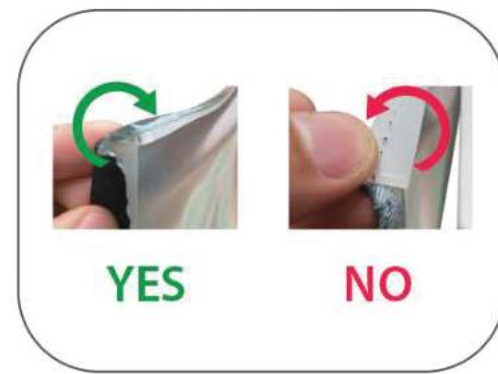

Insert the silicone beading with the fabric folded over. The silicone beading should not be exposed.

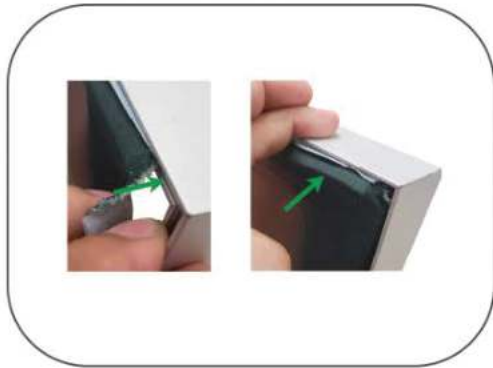

Using your fingers, push both fabric and silicone beading completely into the extrusions channel.



Continue to push in the remaining silicone beading on each side.



Check the perimeter of the frame for any excess beading that hasn't been pushed in. Graphic should be taut.